

# AXLE-LESS

TRAILER SUSPENSIONS



Product Guide

# Escape The Ordinary

Explore. Discover new territory. Do something a little out of the ordinary. You want to go off-road? Maybe plan an epic overland adventure?

In order to pursue your adventure, you're going to need (among other things) a proper trailer. A trailer that can go where you want to go.

Needless to say, you're going to need something out of the ordinary.

You're going to need the Axle-Less trailer suspension. Why? Because there's no thru axle. And when you're exploring off-road, that can make a world of difference.

Escape the ordinary!



TIMBREN

# Cut From A Different Cloth

---

Escape to a completely new experience in trailer suspension technology. The Axle-Less suspension meets a much higher standard in efficiency, quality, and originality. Discover the freedom of the Axle-Less suspension.

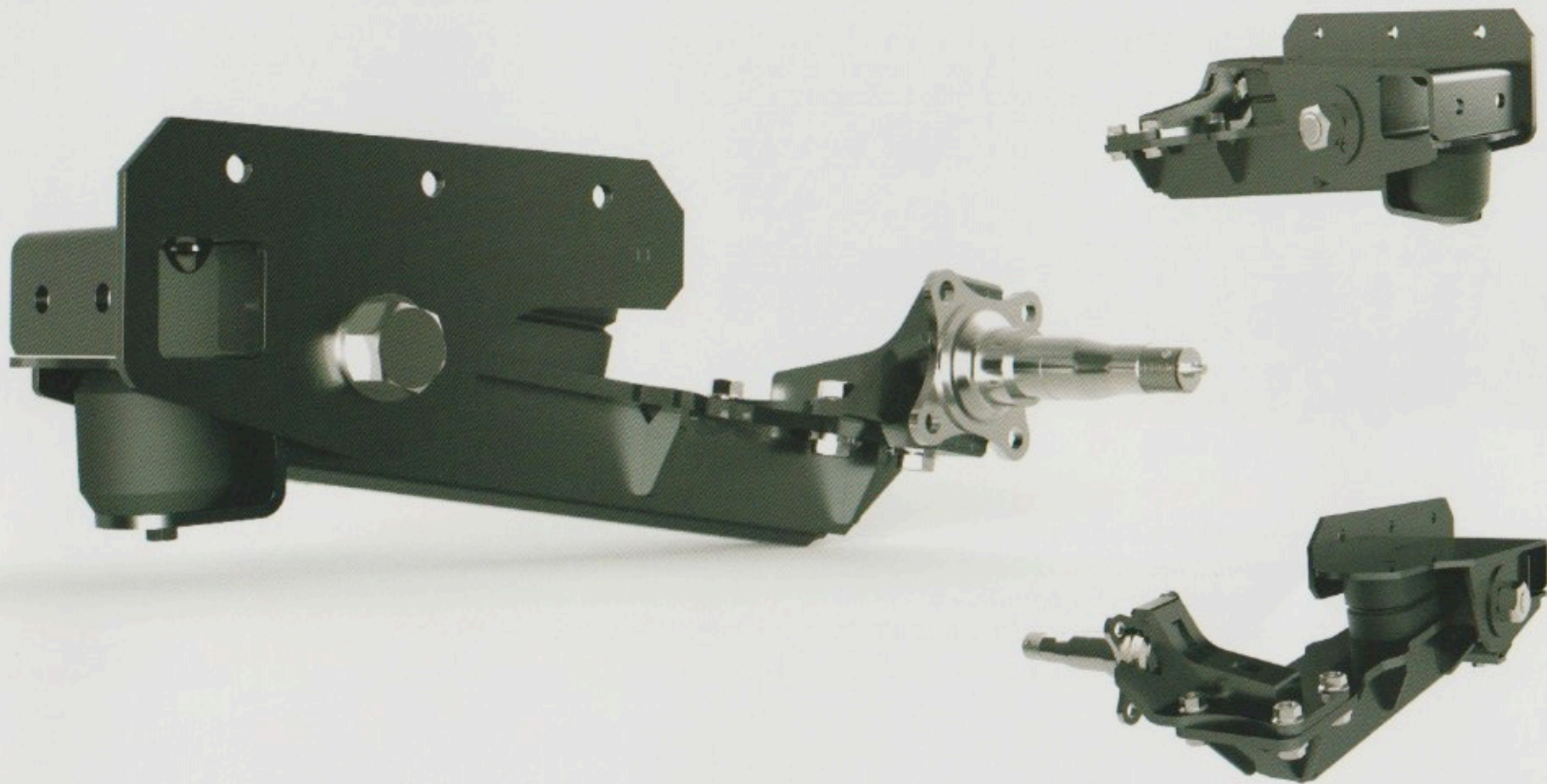

**TIMBREN**

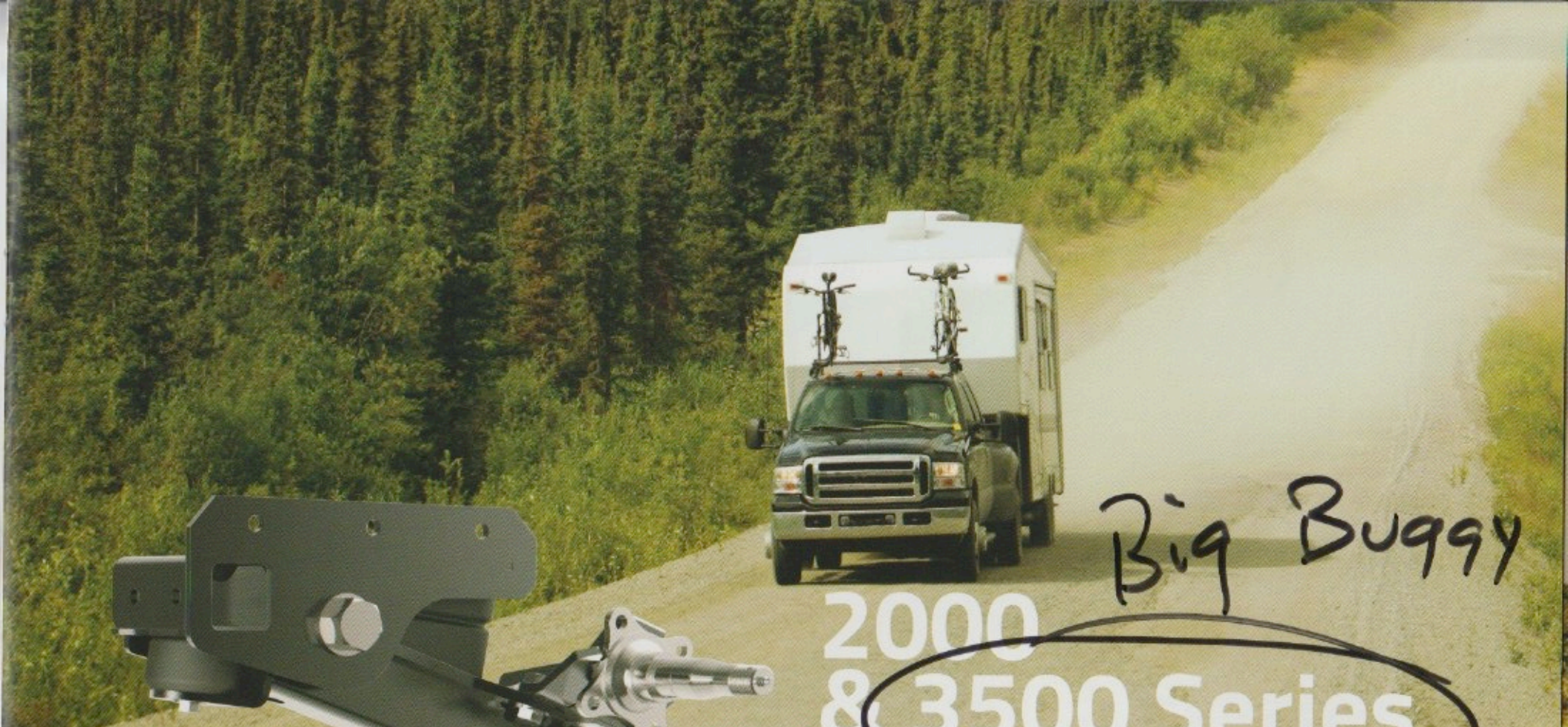

Big Buggy

2000  
& 3500 Series



The 2000 & 3500 series Axle-Less suspensions are perfect for landscape, boat and RV trailers. The 4" drop outboard arm option brings the bed of the trailer down to a height that is easier for loading and unloading on landscape trailers and boat trailers.

If you design trailers, the Axle-Less suspension could be the ingredient that takes your next trailer project to another level. The 2000 & 3500 series options include a regular straight, 4" lift and 4" drop outboard arm.

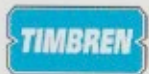



# 2000HD & 3500HD Series

## Little Buggy

When your adventure getaway involves something out of the ordinary, you're going to need our beefed-up HD series. The heavier design of the HD series enables your trailer to endure the abuse of the world's harshest trails. Whether you're in the rugged Australian outback or the harsh climate of northern Canada, the HD series will carry you where you need to go and back again.

The HD series offers 5 outboard arm configuration options. For the maximum in off-road capability you can use the 4" lift option (for better clearance), and a longer spindle to accommodate wide wheel and tire combinations.

See last page for available outboard arm options.

### Steel Hanger

Laser-cut holes in hanger for easy, bolt-on installation. 2" square hole allows use of steel pipe for frame reinforcement.

### Finish

All models available galvanized or powder coated.

### Jounce Spring

Natural rubber compound creates smooth and quiet ride at all times. Unique shape & progressive spring rate allows for variable load conditions.

### Built-In Camber

Camber appropriate to the suspension capacity has been built into the design of all models.

### Rebound Spring

Small, rubber spring creates constant tension on jounce spring. Full or empty, your trailer maintains a smooth ride.

### Bushings

Premium urethane bushings have small grooves allowing grease to lubricate pivot point effectively.

### Outboard Arm

Break a spindle? No problem! Four bolts allow you to switch outboard arm configuration easily.

### Easy Lube Spindle

Designed for easy maintenance. Shoot grease through easy-access nipple for maximum lubrication.

